

**Technical requirements:**

- 100% short circuit test is required for the product;
- conductor resistance: 3 ohm (max);
- insulation resistance: DC 300V 10m ohm (min);
- the product appearance shall be free of contamination, shrinkage, glue punching, deformation, mottled and other defects;
- all materials shall comply with ROHS environmental protection standards;
- thread cutting: l=410mm
- waterproof test grade requirements: IP68;

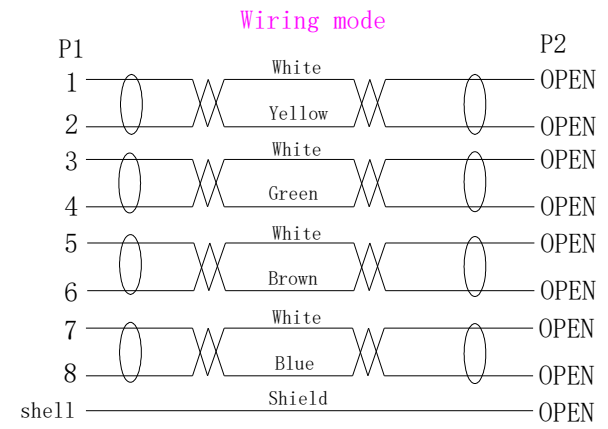

⑧	胶水	Black temperature resistant slow drying a/b glue (epoxy resin) 4:1	5g
⑦	胶圈	Green waterproof fluorine rubber ring: Φ 7*1.5MM	1pcs
⑥	胶圈	Green waterproof fluorine rubber ring: Φ 13*2MM	1pcs
⑤	螺母	M16*1.5mm brass nickel plated nut l*w=2.8*18mm	1pcs
④	屏蔽壳	M12 brass nickel plated shield shell l=23mm	1pcs
③	外壳	M12 brass nickel plated female head front lock shell m16*1.5mm outer tooth l=18.8mm	1pcs
②	插头	M12 X-type 8p female plug black rubber core terminal gold plating	1pcs
①	线材	SSTP CAT. 6A 26awg (7/0.16bc*1.1fm-pe+al*4p yellow white / White Blue White brown white +b 96/0.10tc od:6.5mm covered black PVC wire	0.4m
ITEM	PART NAME	DESCRIPTION	QTY

<http://www.jh-com.com> <http://connectors-cable.com>

UNDECLARED TOLERANCE		CUS P/N:	骏慧兴业科技有限公司		
X. ±1.0	X. ° ±2.0°		Shenzhen JH-C Precision Technology CO		
.X±0.5	.X° ±1.0°		PART NO.:	TITLE:	
.XX±0.2	.XX° ±0.5°	610987-01	M12 X-type female front panel m16*1.5 with shielded shell and cable l=0.4m		
UNITS: MM		APPD.:	DWG NO.:		
THESE DRAWINGS AND SPECIFICATIONS ARE THE PROPERTY OF JH-COM AND SHALL NOT BE REPRODUCED, COPIED OR USED IN ANY MANNER WITHOUT THE PRIOR WRITTEN CONSENT OF JH-COM.		CHKD.:	SCALE	SHEET	REV.
		DR.:	1:1	1/1	A
		HWJ_06/03/22'			